

*Pichugin S.F., DSc, Professor
ORCID 0000-0001-8505-2130*

*Chichulin V.P., PhD, Associate Professor
ORCID 0000-0003-1838-7269*

*Chichulina K.V., PhD, Associate Professor
ORCID 0000-0001-7448-0180*

Poltava National Technical Yuri Kondratyuk University

SPATIAL STRUCTURES OF CLOSED PROFILES

The article presents a new design of steel space trusses, arches, frames of complex application, the main advantages of which are lightness, durability of plane, cost efficiency, reliability, reduction of construction period and investment cycle, energy savings at manufacture, transportation and construction. Based on the previously performed experimental and theoretic studies, the expediency of using box-shaped section parallel chord trusses has been proved. Therefore, new constructive decisions for light efficient trusses, arches, frames that can be used at erection of civil and industrial objects are presented below. The suggested efficient structure of a steel truss with spatial upper chord, using tubes or rectangular hollow box-shaped sections, steel trifurcate spatial truss construction, spatial arch truss, spatial arch. Considered the use of closed cross-sections for spatial arch elements. It has been revealed that using the two-hinges spatial frame the construction cost of a building can be reduced due to reducing of the basement's dimensions.

Keywords: *steel truss, arch, frame, box-shaped section.*

Пічугін С.Ф., д.т.н., професор

Чичулін В.П., к.т.н., доцент

Чичуліна К.В., к.т.н., доцент

Полтавський національний технічний університет імені Юрія Кондратюка

ПРОСТОРОВІ КОНСТРУКЦІЇ ІЗ ЗАМКНЕНИХ ПРОФІЛІВ

Подано нові ефективні сталеві просторові конструкції ферм, арок, рам комплексного застосування, переваги яких полягають у легкості, стійкості щодо площини, економічності, надійності, скорочення строків будівництва й інвестиційного циклу в цілому, економії енерговитрат при виробництві, транспортування та зведення. На основі проведених раніше експериментальних та теоретичних досліджень доведено доцільність використання ферм з коробчастими перерізами з паралельними поясами, наведено нові конструктивні рішення легких ефективних ферм, арок, рам, які можна застосовувати в будівництві об'єктів цивільного та промислового призначення. Запропоновано ефективні конструкції сталевої ферми з просторовим верхнім поясом з використанням труб або замкнених коробчастих перерізів, сталевої тригілкової просторової ферми, аркової просторової ферми та просторової арки. Розглянуто застосування замкнених перерізів для просторових арочних елементів і просторових перерізів із замкнених профілів для рамних конструкцій. Доведено, що при використанні варіанта двошарнірної просторової рами можна зменшити вартість споруди за рахунок зменшення розміру фундаменту.

Ключові слова: *сталева ферма, арка, рама, коробчастий переріз.*

Introduction. In the design of steel span structures of civil and industrial destination, spatial steel structures have lately acquired prevalence due to their substantial advantages in comparison with the traditional ones. The main advantages of the above type constructions are: considerable reduction of the buildings' weight, erection durability and simultaneous saving of operation costs. In general, the construction decisions efficiency is aimed to obtain the most feasible indices of material consumption, manpower efforts and capital intensity of construction. Efficiency indices can be raised due to light efficient box-shaped sections and new contours of trusses, arches and frames with space lattice.

At the current stage of the metal structures market development, ever more popularity is being gained by new types of cross-sections, such as curved box-shaped, profiled and perforated sections. Therefore, popularization of such structures is inducing development of efficient constructive elements and the respective standard regulations for calculation of the given type constructive forms. At present, under the conditions of the nationwide resource saving program, the topical issue is designing new constructive forms and structures' contours, using present-day efficient materials, raising their corrosion resistance and durability. In the building construction industry there is a necessity of using innovative technological developments at erection of public, administrative, storage and industrial buildings and structures.

Latest sources of studies and publications review. The integrated assessment and systematization of the existent building structures referring to the said type of the civil and industrial objects has been the subject matter of the research papers [1 – 6]. Results of the authors' research, namely combined arch-core elements in flat structures, are described in [7]. Patent projects, where the structures under study consideration has been started, are presented in publications [8, 9]. Foreign research developments, presenting a large number of light metal structures, such as trusses, arches, frames, and specifying the advantages and faults of the above type structures, are referred to in the following papers [10 – 15].

Part of the problem not solved before is the fact that at the fast rates of building construction development in our country, the demand of searching new efficient, high-tech, resource saving constructive forms and cross-sections of light metal structures.

Aims of the study. Based on the foreign and national experience of using light steel structures, aim of the study has been formulated as: development of new constructive decisions for trusses, arches, frames, and determining their main advantages compared to the traditional decision variants.

Basic material presentation. Based on the previously performed experimental and theoretic studies [7], the expediency of using box-shaped section parallel chord trusses has been proved. Therefore, new constructive decisions for light efficient trusses, arches, frames that can be used at erection of civil and industrial objects are presented below. The suggested efficient structure of a steel truss with spatial upper chord, using tubes or rectangular hollow box-shaped sections (Fig. 1, a) [9].

Structural peculiarity of the above trusses lies in the fact that the truss's upper chord is made trifurcate, thus providing its stability both in the plane and out of the truss's plane (Fig.1, b, c). In all the cases, the cross-sections are made of tubes or rectangular profiles. The distance between the chord's branches makes $1/6 - 1/8$ of the truss's height and is determined by the calculation of upper chord's stability. The truss's height depends on the parallel chord trusses' span and provides the necessary stiffness of the structure.

As the following stage of using the rectangular hollow sections, let us consider the steel trifurcate spatial truss (Fig. 2). Efficient operation of this structure is determined by the truss's spatial rigidity both in the plane and out of the truss's plane. Disengagement of the truss's upper chord with joists, on which a profiled decking is mounted, forming a rigid decking disk. The lower chord of a spatial truss is disengaged by a system of braces, providing the trusses'

stability out of the plane. Using rectangular cross-sections is technologically more expedient than using round tubes that require additional equipment for shape-cutting. The above described structures cover a definite surface and are more economically efficient when comprehensively used for covering. Spatial trusses have less construction height than flat ones that sometimes sufficiently reduces the construction costs.

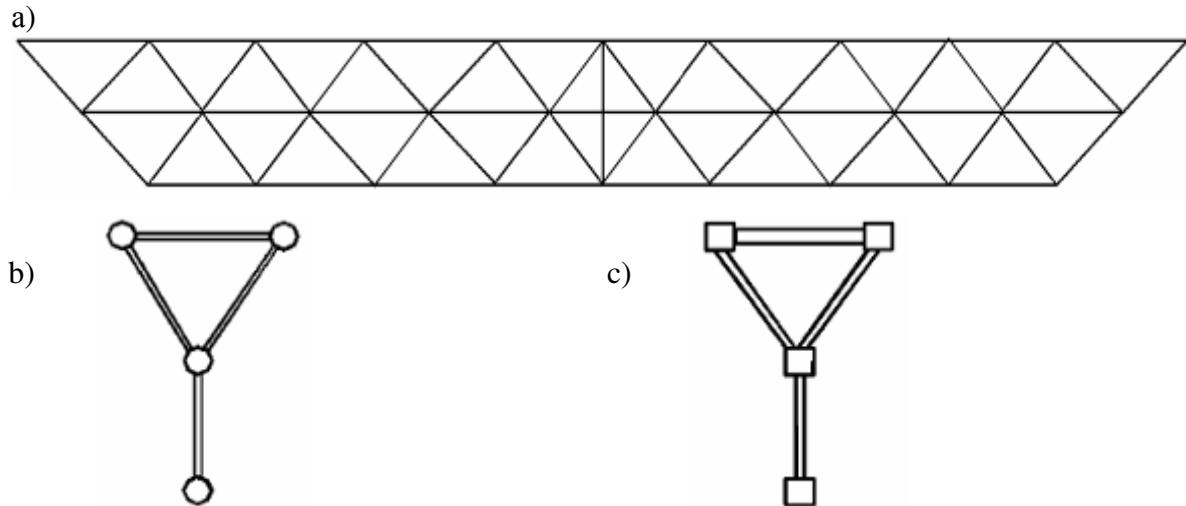

Figure 1 – Truss with a spatial upper chord:

- a) diagram of a truss with a spatial upper chord;
- b) cross-section of trusses with a spatial upper chord made of tubes;
- c) cross-section of trusses with a spatial upper chord made of rectangular profiles

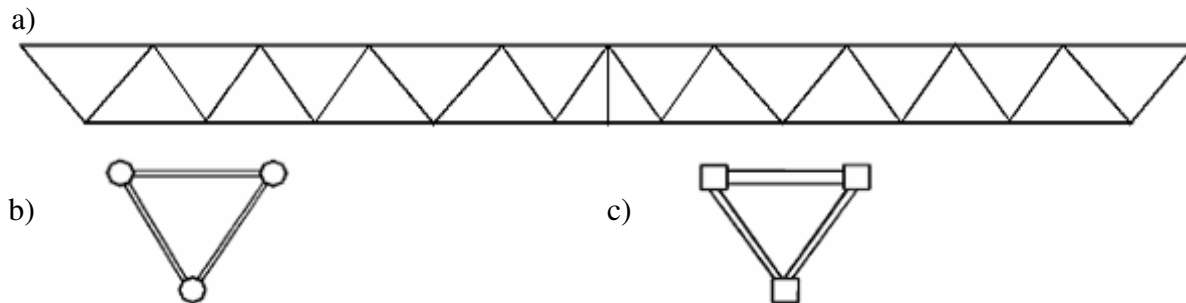

Figure 2 – Spatial truss made of closed hollow profiles:

- a) diagram of a truss made of closed hollow profiles;
- b) truss cross-sections made of tubes;
- c) truss cross-sections made of rectangular profiles

Let us consider the use of closed cross-sections for spatial arch elements. Figure 3, a describes an arch spatial truss and a spatial arch (Fig. 3, b). As to the metal consumption, arch covering is more economizing than the beam systems.

In the course of the study performed it has been determined that the most expedient height of the arch lies within $1/4 - 1/6$ of the span. The arch contour should maximally correspond to the pressure curve. The pressure curve in the arch has a parabolic contour due to the persistent pressure, therefore, the most frequent arch form is recognized to be parabolic. However, for ease of manufacture, arch elements are often delineated in a circular arc. In flat (depressed) arches the circular arc is almost coinciding with the parable, whereas in higher arches it is reasonable to substitute the parable with a combination of circular arcs of different radii.

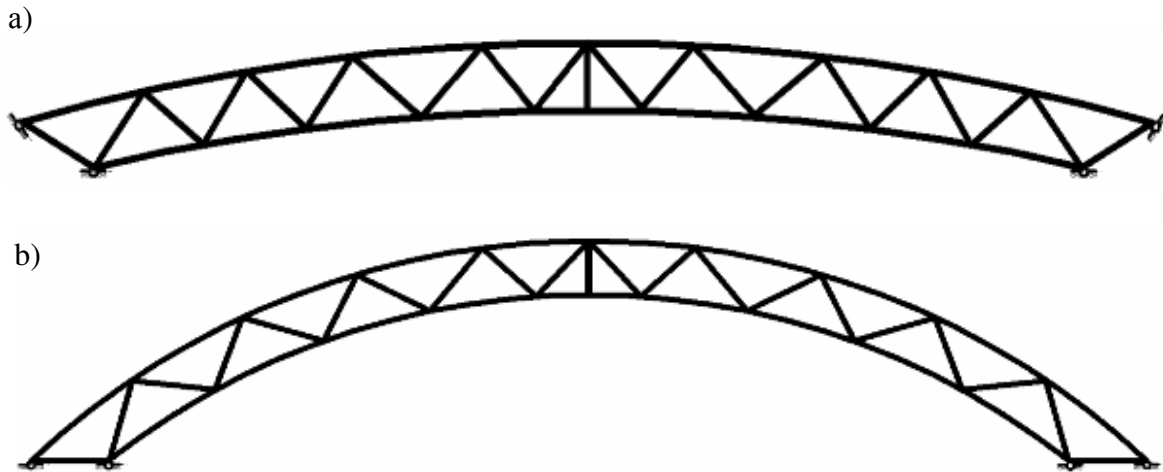

Figure 3 – Steel spatial arch structures:
 a) spatial arch truss; b) spatial arch

The arch section's height depends upon the span and the ratio of the dead and live load values and is assumed for braced arches within $1/30 - 1/60$ of the span, for solid sections it makes $1/50 - 1/80$ of the span.

Spandrel arches cross-sections are recommended to be of a fixed height, which is meeting the nature of the efforts length changes to the fullest extent. Meanwhile, in many cases, variable height cross-sections are used, for example, crescent type arches in two- and three-hinged arch covers.

Using spatial sections of closed profiles for frame structures will be considered in the context of traditionally contoured hingeless (Fig. 4, a) and two-hinges frames (Fig. 4, b).

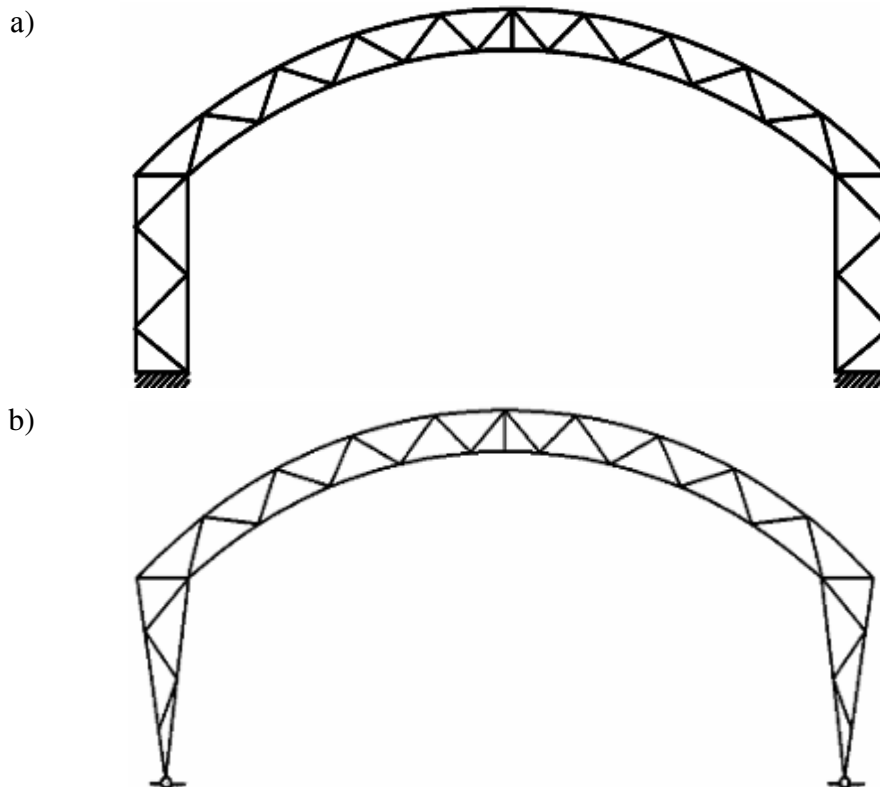

Figure 4 – Steel spatial frame structures:
 a) hingeless spatial frame; b) two-hinges spatial frame

The trifurcate system's spatial behaviour provides rigidity in the plane and out of the frame's plane. The main advantages of the frame covers compared to the beam ones are: less weight, high rigidity and less frame beam's height. Frame beams' sections are mostly designed built-up for spans up to 60 m long, particularly when the frame's beam has a broken contour. Frame structures are efficient when the columns' and beams' rigidity is equal, thus permitting to redistribute the vertical loads' efforts and to considerably lighten the beams: in this case the braced beam's height can be assumed equal to 1/12 – 1/20 of the span.

Manpower effort's growth at spatial structures manufacturing is exceeded by their reduced material consumption thus giving the possibility of obtaining more economizing structures.

As a result of the performed study, it has been revealed that using the two-hinges spatial frame (Fig. 4, b) the construction cost of a building can be reduced due to reducing of the basement's dimensions.

Conclusion. The suggested new constructive decisions for steel spatial trusses, arches and frames, having the properties of high load bearing capacity and architectural expression, minimize material and manpower expenses. The described type structures demonstrate the increased indices on the general stability of separate elements and of the whole system both in the plane and out of the plane.

References

1. Бирюлев В. В. Стальные фермы с коробчатыми сечениями стержней, сваренных из уголков / В. В. Бирюлев // Известия вузов. Серия: Строительство и архитектура. – 1973. – С. 8 – 14. Biryulyov V. V. Steel trusses with box-shaped sections of chords welded of cleats / V. V. Biryulyov // Higher School News, Series: Construction and Architecture. – 1973. – P. 8 – 14.
2. Металлические конструкции: Справочник проектировщика / Под ред. Н. П. Мельникова. – М. : Стройиздат, 1980. – 776 с. Metal structures: Designer's reference / Under the editorship of N. P. Melnikov. – M. : Stroyizdat, 1980. – 776 p.
3. Абаринов А. А. Особенности работы и расчета ферм из труб / А. А. Абаринов, Н. Б. Козьмин, А. Ф. Кузнецов // Промышленное строительство. – 1970. – № 6. – С. 32 – 36. Abarinov A. A. Features of behaviour and calculation of tube trusses // A. A. Abarinov, N. B. Kozmin, A. F. Kuznetsov // Industrial construction. – 1970. – № 6. – P. 32 – 36.
4. Павлов А. В. Методологические основы современной системы принципов формообразования строительных конструкций / А. В. Павлов, В. М. Фридкин // Архитектура и строительство. – М. : Академия, 2010. – № 1. – С. 70 – 73. Pavlov A. V. Methodological fundamentals of the present-day building structures shape forming principles system / A. V. Pavlov, V. M. Fridkin // Architecture and construction. – M. : Academia, 2010. – No 1. – P. 70 – 73.
5. Типизация и стандартизация металлических конструкций / В. В. Кузнецов, В. В. Ларионов, Б. Г. Павлов и др. // ЦНИИПроектстальконструкция им. Мельникова: сборник научных трудов. – М., 1987. – 133 с. Typing and standardizing of metal structures / V. V. Kuznetsov, V. V. Larionov, B. G. Pavlov et al. // Melnikov CNII Proektstakonstruksia: collection of research papers. – Moscow, 1987. – 133 p.
6. Металлические конструкции / Ю. И. Кудишин, Е. И. Беленя, В. С. Игнатьева и др. – М. : Академия, 2010. – 688 с. Metal structures: / Yu. I. Kudishin, Ye. I. Belenya, V. S. Ignatyeva et al. – M. : Academia, 2010. – 688 p. ISBN: 978-5-7695-6706-3.
7. Пічугін С.Ф. Застосування комбінованих арочно-стрижньових елементів в плоских конструкціях / С. Ф. Пічугін, В. П. Чичулін, К. В. Чичуліна // Ресурсоекономні матеріали, конструкції, будівлі та споруди: зб. наук. пр. – Рівне: НУБГП, 2014. – Вип. 28. – С. 399 – 404.

Pichugin S. F. Using combined arch and chord elements in flat structures / S. F. Pichugin, V. P. Chichulin, K. V. Chichulina // Resource saving materials, structures, buildings and constructions: collection of research papers. – Rivne: NUVGP, 2014. – Issue 28. – P. 399 – 404.

ISSN: 2218-1873.

8. Пат. 98332 Україна, МПК (2006) Е 04 С 3/02. Ресурсоєкономна комбінована металева конструкція / Пічугін С. Ф., Чичулін В. П., Чичуліна К. В.; власник: Полтавський національний технічний університет ім. Юрія Кондратюка. – № u201411961; заявл. 05.11.2014; опубл. 27.04.2015.

Patent 98332 Ukraine, IPC (2006) E 04 C 3/02. Resource-saving combined metal structure / Pichugin S. F., Chichulin V. P., Chichulina K. V.; Holder: Poltava National Technical Yuri Kondratyuk University. – № u201411961; submit. 05.11.2014; publ. 27.04.2015.

9. Пат. 98331 Україна, МПК (2006) Е 04 С 3/02. Комбінована металева конструкція ферми / Пічугін С. Ф., Чичулін В. П., Чичуліна К. В.; власник: Полтавський національний технічний університет ім. Юрія Кондратюка. – № u201411960; заявл. 05.11.2014; опубл. 27.04.2015.

Patent 98331 Ukraine, IPC (2006) E 04 C 3/02. Truss combined metal structure / Pichugin S. F., Chichulin V. P., Chichulina K. V.; Holder: Poltava National Technical Yuri Kondratyuk University. – № u201411960; submit. 05.11.2014; publ. 27.04.2015.

10. *Plate-Girder Construction (Classic Reprint) // Isamu Hiroi. – Publisher «book on demand», 2015. – 116 p.*

ISBN: 9781332027699.

11. *Notes on Plate-Girder Design (Classic Reprint) // Clarence W. Hudson. – Publisher «book on demand», 2015. – 96 p.*

ISBN: 9781177410045.

12. *Mechanics of the Girder // John Davenport Crehore. – Publisher «book on demand», 2015. – 594 p.*

ISBN: 9781332336340.

13. *Modified method of Prestressing Steel Trusses by inducing Lack of fit // Ponnada Markandeya Raju and Thonangi Raghuram Sandeep. – LAP Lambert Academic Publishing, 2012. – 168 p.*

ISBN: 9783659317743.

14. *Chord Bearing Capacity in Long-span Tubular Trusses // Brian Kozy. – Scholars' Press, 2013. – 172 p.*

ISBN: 9783639515541.

15. *Advanced Analysis of Steel Frames // Huu-Tai Thai. – Scholars' Press, 2012. – 180 p.*

ISBN: 9783639510171.

© Pichugin S., Chichulin V., Chichulina K.

Received 25.10.2016