

UDC 624.13

Resistance of tubular piles shear silk along surfaces

Tugaenko Iurii^{1*}, Tkalic Anatoliy², Shekhovtsov Ihor³, Petrash Svetlana⁴

¹ Odessa State Academy of Civil Engineering and Architecture

² Odessa State Academy of Civil Engineering and Architecture <https://orcid.org/0000-0003-4859-0233>

³ Odessa State Academy of Civil Engineering and Architecture <https://orcid.org/0000-0003-3664-0723>

⁴ Odessa State Academy of Civil Engineering and Architecture <https://orcid.org/0000-0002-8567-3962>

*Corresponding author: list@ogasa.org.ua

The results of piles tests in sea muddy soils underlain by loams and clays are presented at port berths in Odessa region. Piles length 28.0 and 34.0 m have been made of metal pipes with a diameter of 1400 mm with a wall thickness of 16 mm. From the sea water surface to the silt roof is 15.0 m. The lower end of the two tubular supports (piles) has been located above the silt sole that enables the test piles to be brought to "breakdown" and determine its resistance (silt) along the outer and inner surfaces. According to the test results, the piles are increased by 6 m that enables to use the underlying soils as a bearing layer. Tests of piles have been carried out according to the standard procedure, for the reference system, two additional tubular supports with a diameter of 1400 mm were placed in the vicinity of the test subjects.

Keywords: metal tubular pile, sea muddy soils, muddy soils resistance to shear along trunk surface

Опір зрушенню мула вздовж поверхонь трубчастих паль

Туґаєнко Ю.Ф.^{1*}, Ткаліч А.П.², Шеховцов І.В.³, Петраш С.В.⁴

¹ Одеська державна академія будівництва та архітектури

² Одеська державна академія будівництва та архітектури

³ Одеська державна академія будівництва та архітектури

⁴ Одеська державна академія будівництва та архітектури

*Адреса для листування: list@ogasa.org.ua

Наведено результати випробувань паль у морських мулких ґрунтах, що підстиляються суглинками і глинами, на причалу порту в Одеській області. Палі завдовжки 28 і 34 м виконано з металевих труб діаметром 1400 мм з товщиною стінок 16 мм. Від поверхні морської води до кривлі мулу – 15,0 м, товща мулу – 13,2 м. Нижній торець двох трубчастих опор (паль) розташовувався вище за підшову мулу, що дозволило довести випробовувані палі до «зриву» та визначити його опір по зовнішній і внутрішній поверхнях. За результатами випробувань палі нарощено на 6 м, що дозволило використати як несучий шар розташовані нижче ґрунти. Випробування паль здійснено за стандартною методикою, для реперної системи було занурено додатково дві трубчасті опори діаметром по 1400 мм біля випробовуваних. Згідно з розрахунками середнє значення граничного опору зрушенню для двох паль, які розташовані в морських мулких ґрунтах, склало 17,3 кН/м² (17,3 кПа) і 15,4 кН/м² (15,4 кПа). Для порівняння дослідження опору обводнених лесовидних супісків показали, що їх величина трохи вища за морський мул і складає 20 кПа. Для визначення опору ґрунтів основи по поверхні паль застосовано методику циклічно-зростаючого навантаження. Граничне навантаження, урівноважене опором зрушенню паль, заглиблених у мул, із зовнішнього і внутрішнього боків склали 1980 та 1760 кН. З'ясовано, що після нарощування палі несуча здатність збільшилася за рахунок опору нижче торцевої частини. При повному навантаженні P=3000 кН осідання палі склало 5,45 мм. Установлено, що граничний опір ґрунтів зрушенню по поверхні стінок опори P_T = 1909 кН, а опір ґрунту під торцем стінок палі P_R = 1091 кН. Виявлено, що в процесі проходки трубчастої палі її стінками «прорізається» шар мулистого ґрунту.

Ключові слова: металева трубчаста паля, морські мулісті ґрунти, опір мулистих ґрунтів



Introduction. Designing the shallow foundations and pile foundations for buildings and structures, when there are engineering-geological elements from mud grounds in the earth cover, as a rule their resistance to the loads is usually not considered. Under the heavy thickness of these soils, knowing their resistance value, it is possible to partially reduce the effect of the load on the bearing soil layer.

Analysis of recent sources of research and publications. Constructing buildings and structures in the cities of Riga, Odessa and Sukhumi, K. Ehorov noted the special properties of highly compressible soils. At large thicknesses, the arrangement of sand cushions is not effective, they need to be cut with jointed piles.

Selection of previously unsettled parts of the general problem. In the tests, the resistance values of silk on the outer and inner surfaces of metal tubular piles were determined.

Task definition. To carry out the full-scale studies of the marine mud resistance.

Basic materials and results. Resistance characteristics of foundation soil to the loads, transmitted by pile, are shear strength over the shaft surface and the compression below the toe. Studying stress-strain state, conducted in the field conditions with the use of special equipment, two methods of soil resistance determining over the pile surface are used:

- Integral one, based on the average determination of soil shear strength over the entire surface;
- Differential one, which is based on soil shear strength determination in some spots with the help of strain gauges [1].

The applied technique of cyclic-increasing load enables to determine the soil resistance of the foundation over the pile surface [2, 3, 4]. It considers pile shaft elastic compression from each load stage without special equipment use.

The soil shear strength over the pile surface (f) appears after the load application. It is balanced on the compressible part of the length by shear resistance that depends on the soil properties. The elastic compression along the pile length occurs consistently with load increasing. A part elastic compression $s_{y,i}$ of the length $l_{f,i}$ corresponds to each load stage P_i . Within this length, the applied load is balanced by the shear resistance. Experiments proved that the shear resistance limit value, at the consequential increasing of the load, is retained in pile previous sections.

Elastic deformation consists of elastic-instantaneous and elastic-viscous parts. The elastic-instantaneous part is almost 90% of the total one and it disappears almost after the load is removed, and deformation elastic-viscous part relaxation lasts several hours. In the performed tests, deformation elastic-instantaneous part values were used.

The method of research is :

1. Piles tests for vertical or pulling static loads have been carried out in steps until the conditional stabilization of the settlement(s) is reached.

2. Once the stabilization of the settlement has been achieved and measured, the load is removed (reset to zero). The settlement residual part is measured at this stage (s_o).

3. The difference between settlements of stabilized stage (s) and residual one (s_o) is the elastic part (s_y).

4. The dependence graph $s_y = f(P)$ is constructed, where the breaking point of the line divides it into two branches and shows the size of the soil resistance (P_f) along pile ultimate load surface.

5. Shear resistance value (f) is determined as the quotient by dividing the load corresponding to the ultimate shear resistance (P_f) on the shaft surface area (A_f).

It is not always possible to use the method of cyclic-increasing load to determine the elastic settlement, so with some error it is possible to determine the ultimate load of soil resistance to the shear (P_f) on the dependency graph $s = f(P)$, lengthening two branches of the graph to their intersection.

At one of the port berths in Odesa region, the metal tubular piles were tested in mud ground, underlain by loam and clay. The ground conditions of the construction site are represented by the following layers (Fig. 1).

The averaged values of the soil physico-mechanical characteristics for each EGE are given in Table 1.

The penetration of metalpipes (piles) with the diameter of 1400 mm, the depth of 16 mm was carried out with a hydraulic chammer. Testing of control piles was carried out with the help of hydraulic jack *DV-400-200* with its support on the stop bar. For the installation of measuring instruments (deflection indicators), two additional supports were loaded near the test pile (Figure 2).

From the sea water surface to the silt top, the depth was 15.0 m. According to DBN B.1.1-12: 2014 (maps ZSR 2004), the area refers to the seismic zone with 6 earthquake intensitie sand 10% probability, with 7 earthquake intensitie sand 5 % probability and to the zone with 7 earthquake intensitie sand 1% probability (earthquake intensity of the scale MKS-64).

The control tests were carried out according to the standard procedure. Each stage of the load was supported to the conditional stabilization, not exceeding 0.1 mm for the last 60 minutes of observations. Two piles (№№. 259, 215) with the length of 28.0 m were tested. The external static load, applied to the supports, is balanced by the sum of the shearing forces on the contact from soil inner and outer sides and the surface. Before overcoming the ultimate shear strength, the tubular support is compressed elastically (s_y), remaining stationary. At the load, exceeding the limiting resistance, there is a sharp increase of the settlement as a result of its movement.

The lower ends of the tubular supports (piles) were located above the silt bottom, which allowed to «break» the mand determine the soil resistance along the outer and inner surfaces (Fig. 3). The ultimate load, balanced by the pile shear resistance (strength),

buried in the silt, from outer and inner sides was 1980 kN (Fig. 4).

According to the calculations, the average value of the ultimate shear resistance was 17,3 kN/m² (17,3 kPa). In comparison, the studies of flooded resistance sandy loam have shown that its value is much higher than sea mud and it is 20 kPa [4].

The ultimate load, balanced by the shear strength of the support (pile) № 215, buried in the silt, from the outer and inner sides was 1760 kN (Fig. 5). According to the calculation, the ultimate shear strength average value was 15.4 kN/m² (15.4 kPa).

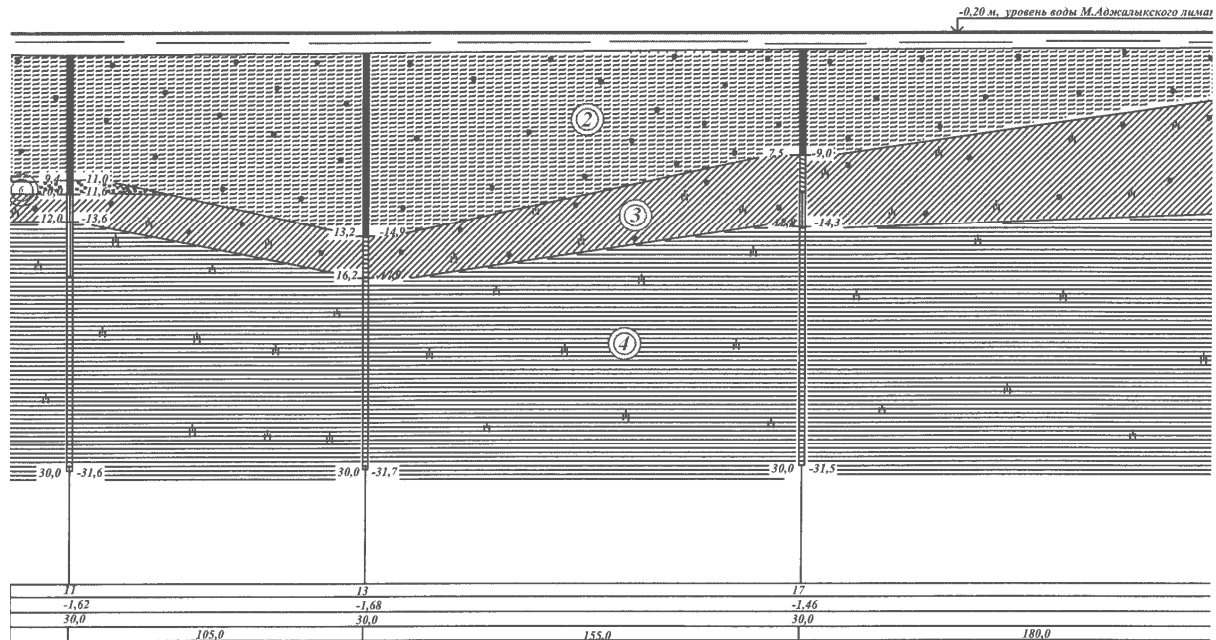

**Figure1 – Engineering geological section:
EE-2 – seamud; EGE-3 – heavyloam; EGE-4 – light clay**

EGE-2 – sea loamy mud is dark grey with sandy silt bands, the addition of the shells, an admixture of organic substances and hydrogen sulfide flavor; fluid.

EGE-3 – heavy loam is greenish-grey, brownish-grey, with the addition of land waste and crushed limestone; semisolid.

EGE-4 – light clay is light-grey, with ocher spots, ferruginous; semisolid.

Table 1 – Index of soil properties

№ EGE	Kind of soil	ρ_s g/cm ³	ρ_d g/cm ³	w	I_L	S_r	E_s MPa	φ	c_s MPa
2	Sea loamy mud	2.45	0.01	0.56	1.552	0.97	2	4	0.012
3	Sandy loam	2.71	1.62	0.26	0.123	0.83	25	19	0.030
4	Clay	2.73	1.64	0.23	0.02	0.93	40	14	0.10

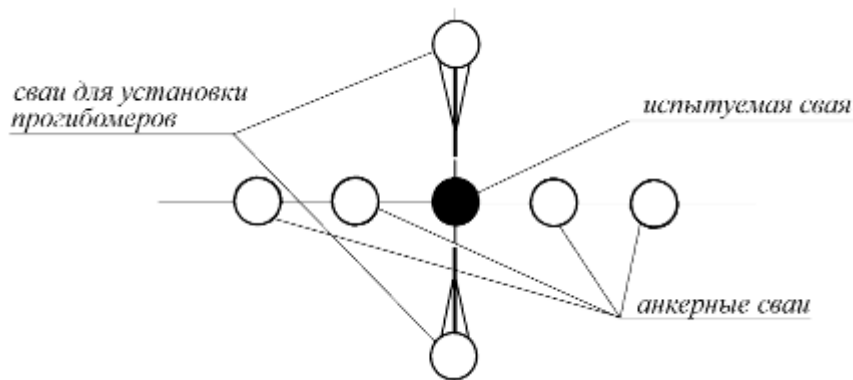

Figure 2 – Scheme of the test complex

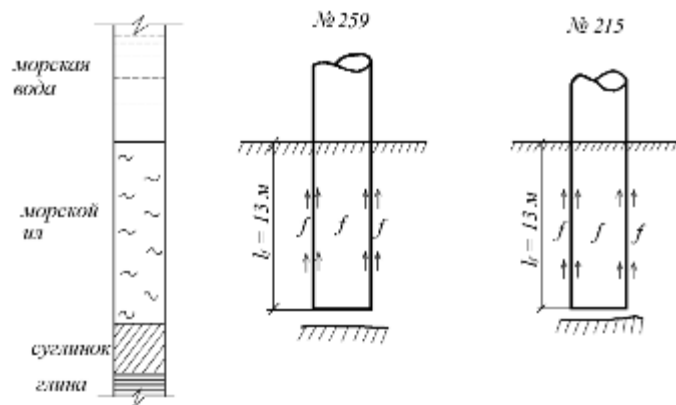

Figure 3 – The scheme of soil resistances (f) in tubular piles

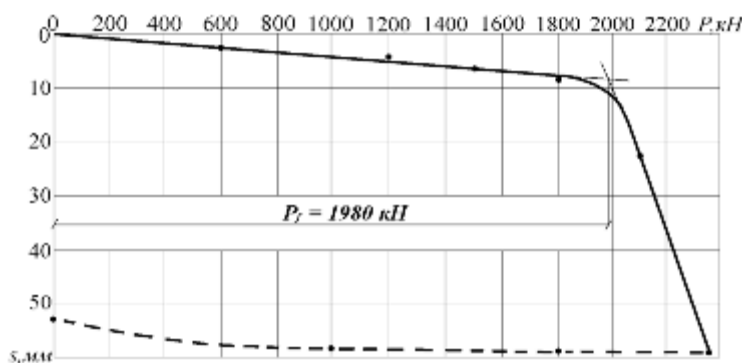

Figure 4 – Dependency graph of settlement along of the load for the support (pile) No. 259:

P_f is the load which is equal to the ultimate shear strength at the contact of the support walls with the surrounding soil

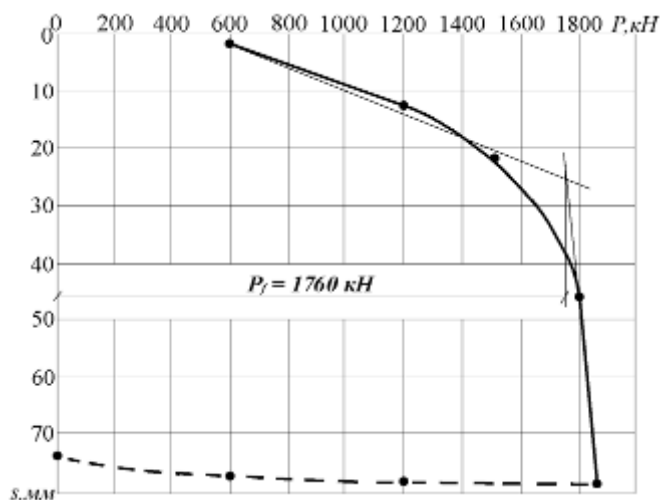

Figure 5 – Dependency graph of the settlement along of the support load (pile) № 215:

P_f is the load which is equal to the ultimate shear strength at the contact of the support walls with the surrounding soil

The test results showed that to achieve the design load on the piles, they must be extended. Pile № 254 was elongated by 6 m, which enabled its butt end to enter the soil layers lying below the silt bottom, and then its bearing capacity increased due to the resistance below the butt end (P_R).

During the penetration of a tubular pile, its walls «cut through» a layer of muddy soil. The top of the silt level from the outer and inner sides of the tubular (caisson) support ranged within $\pm 18 \dots 20$ cm. The research results of two piles, supported on muddy grounds, and the third one, which butt end buried into the underlying soils, are summarized in Table 2.

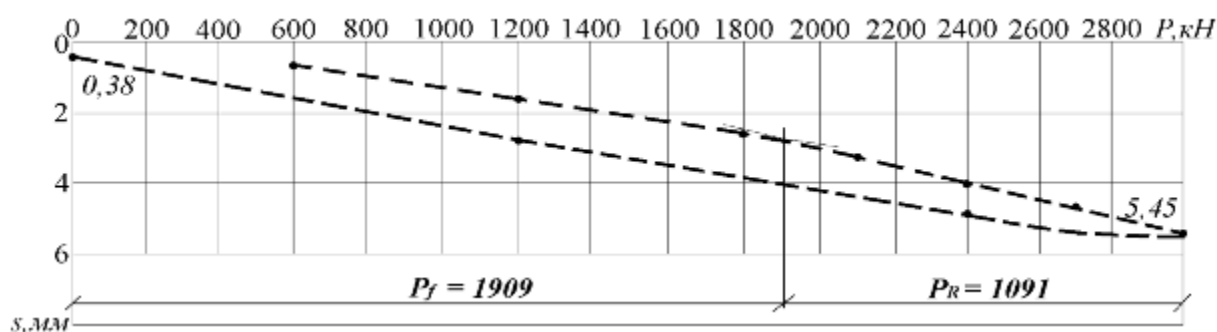

Figure 6 – Dependency graph of the settlement along of the support load (pile) № 254:
 P_f is the load which is equal to the ultimate shear strength at the contact of the support walls with the surrounding ground, the resistance below the butt end (P_R)

Table 2 – Key findings

№ Pile	Pile length, m	Load, kN			Settlement, mm		Ultimate shear strength of sea mud (at P_f), f , kPa
		P	P_f	P_R	Full	At P_f	
259	28.0	2350	1980	370	59.87	8.94	17.3
215	28.0	1860	1760	100	79.7	25.1	15.4
254	34.0	3000	1909	1091	5.45	3.04	–

Notes: P – full load; P_f –ultimate soil shear strength along the wall surface of the tubular support; P_R –soil resistance under the butt end of the support walls (piles).

Conclusions:

1. The butt ends of metal piles № 259 and 215 did not reach the sea silt bottom. The ultimate load, balanced by the sea mud shear strength from support outer and inner sides, was 1980 and 1760 kN.
2. Sea silt resistance along the outer and inner surfaces was 17.3 and 15.4 kPa. For flooded sandy loam this value is 20 kPa.
3. The level of the sea silt top from the outer and inner sides of the pile varies within $\pm 18 \dots 20$ cm.
4. With sea silts considerable thickness and considering their resistance, it is possible to reduce partially the load effect on soil bearing layer.
5. According to the test results, all the piles were elongated that enabled their butt ends to bury the soil layers below the silt bottom.

References

1. Григорян, А.А. (1984). *Свайные фундаменты зданий и сооружений на просадочных грунтах*. Москва: Стройиздат.
2. Tugaenko, Y., Marchenko, M., Tkalich, A. & Mosicheva, I. (2015). Peculiarities of the soil deformation process at the bases of experimental settlement plates. *Technical journal Scientific professional journal of University North*, 9(1). 40-46.
3. Tugaenko, Y., Tkalich, A., Marchenko, M., & Loginova, L. (2015). Differential method of estimation of soil resistance characteristic according to the pile test. *Scientific professional journal of University North*, 9(2). 180-185.
4. Тугаєнко, Ю.Ф. (Ред.), Марченко, М.В., Ткалич, А.П. & Логінова, Л.О. (2018). *Природа деформування ґрунтів: монографія*. Одеса: Астропринт.