

Karpiuk V.M., DSc, Professor
ORCID 0000-0002-4088-6489 v.karpiuk@ukr.net
Kostiuk A.I., PhD, Professor
ORCID 0000-0002-5642-2443 pcb.odaba@mail.ru
Somina Yu.A., assistant
ORCID 0000-0002-6330-0137 syomina3091@ukr.net
Odesa State Academy of Building and Architecture

MODELS OF BAY REINFORCED CONCRETE ELEMENTS RESISTANCE AT ACTION OF CYCLE PERMANENT SIGN HIGH LEVEL FORCES

The reinforced concrete span beam structures work with small, middle and large shear spans under the action of cyclic loads of high levels is investigated. It is established that researches of physical models development of bending reinforced concrete elements fatigue resistance to the cyclic action of transverse forces and calculation methods on its base are important and advisable due to following features of said load type: the nonlinearity of deformation, damage accumulation in the form of fatigue micro- and macrocracks, fatigue destruction of materials etc. The key expressions of the concrete endurance limits definition (objective strength), longitudinal reinforcement, anchoring of longitudinal reinforcement, which consists the endurance of whole construction are determined. Also the role and the features of influence of vibro-creep deformations on the change mechanics of stress-strain state of concrete and reinforcement of research elements are investigated.

Keywords: endurance, cyclic load, fatigue destruction.

Карпюк В.М., д.т.н., професор
Костюк А.І., к.т.н., професор
Сьоміна Ю.А., асистент
Одеська державна академія будівництва та архітектури

МОДЕЛІ ОПОРУ ПРОГІННИХ ЗАЛІЗОБЕТОННИХ ЕЛЕМЕНТІВ ЗА ЦИКЛІЧНОЇ ЗНАКОПОСТІЙНОЇ ДІЇ ПОПЕРЕЧНИХ СИЛ ВИСОКИХ РІВНІВ

Досліджено робота залізобетонних прогінних балкових конструкцій з малим, середнім та великим прольотами зрізу в умовах дії циклічних навантажень високих рівнів. Установлено, що розроблення фізичних моделей втомного опору залізобетонних елементів, що згинаються, циклічній дії поперечних сил та методи розрахунку на їх основі є важливими та доцільними через такі особливості вказаного виду навантаження: нелінійність деформування, накопичення пошкоджень у вигляді втомних мікро- і макротріщин, втомне руйнування матеріалів тощо. Визначено ключові вирази знаходження межі витривалості (об'єктивної міцності) бетону, поздовжньої арматури, анкерування поздовжньої арматури, які й складають витривалість усієї конструкції в цілому. Досліджено роль та особливості впливу деформацій віброповзучості на механіку зміни напружено-деформованого стану бетону й арматури дослідних елементів.

Ключові слова: витривалість, циклічне навантаження, втомне руйнування.

Introduction. In the current design standards, the calculation of endurance in bay reinforcement concrete structures is performing under the assumption of concrete elastic work. Calculation of sloping sections is performing under the assumption that main tension stresses, which appears on the level of transformed section centroid, should be fully carried by transverse reinforcement at stresses in it, which are equal to calculation resistance of transverse reinforcement f_{sw} , multiplied on condition load effect factor γ_{sw} , in elements without transverse reinforcement – by concrete at stresses in it, which are equal to concrete calculation tension resistance f_{ctd} , multiplied on appropriate condition load effect factor γ_c .

Such calculation approach contradicts to real work character of inelastic work of reinforced concrete elements and does not display reinforced concrete behavior features in the zone of transverse forces actions at cycling loads, does not display real stress-strain state, does not consider the ambiguity of transverse forces perception by different elements at different shear bays and character of fatigue destruction crack appearance and propagation, does not consider or consider mediated the influence of number of structural factors and factors of external action, which ultimately leads to significant differences between calculated and experimental data.

Analysis of last researches and publications sources. I.T. Mirsayapov, E.M. Babich, N.I. Karpenko [1 – 3] main attention is paid to the study of endurance and stress-strain state of normal sections of elements, which are bent, to the endurance of concrete and reinforcement and their deformability at second loads. During these researches there are accumulated a lot of experimental data, there is proposed a number of practical methods of normal section calculation in the zone of structures pure bending.

Despite the large number of experimental and theoretic researches of I.T. Mirsayapov, E.M. Babich, N.I. Karpenko, F. Aslani, W. Trapko [1 – 5] of reinforcement concrete elements resistance to the transverse forces action at static loads, the problem of reinforced concrete resistance to the second loads action remain is not studied well.

Specifying unsolved aspects of the problem. Theoretical researches of physical models development of bending reinforced concrete elements fatigue resistance to the series action of transverse forces and calculation methods on its base are almost missing. Therefore, today the development of physical models of fatigue resistance and destruction of near support parts of beams, which correctly shows their real work considering real element of concrete and reinforcement deforming at different shear spans and corresponding methods of their calculation has just been started.

Setting objectives. The main aim of the article is to study the performance of reinforced concrete structures by the means of creating these elements common models comprehensive resistance to the action of high levels cyclic loads with different shear spans.

The main material and results.

Reinforced concrete elements resistance models with small, middle and large shear spans.

Researches of I.T. Mirsayapov [1] and other investigators have shown, that at $c_0 / h_0 > 2$ fatigue destruction of near support parts of bending elements occurs with appearance of critical inclined crack, which location is connected not only with points of external force applying and support reaction, but with internal force factors, which occurs in shear span (moments and transverse forces). At $1,2 < c_0 / h_0 \leq 2$ destruction of near support parts of beam elements at cycle load has little similar signs of destruction of elements with small and large shear spans. In this case, conduct of appearing and extension of cracks and fatigue destruction in this zone at indicated load influences internal force factors and local concentrations of stresses in corresponding zones near points of external concentrated forces applying.

The feature of «long» bending reinforced concrete elements work at small shear spans ($a_0 < 1,2h_0$) is appearing of local stress strips, connected with points of concentrated forces applying within which occurs fatigue destruction. This feature of usual reinforced concrete

beams with small shear spans joins them with «short» elements. In both cases this feature occurs at small values of relative distance between forces, applied to element.

B.S. Sokolov [6], T.I. Baranova [7], O.S. Zalesov [8], and others consider that for practical calculations of «short» elements the simplest solution of a problem is formation of calculating model as frame-rod system (FRS) which consists of inclined compressed strips and tensed bottom and compressed top reinforcing zones, which enclosure at points of concentrated forces and support reactions applying (fig. 1).

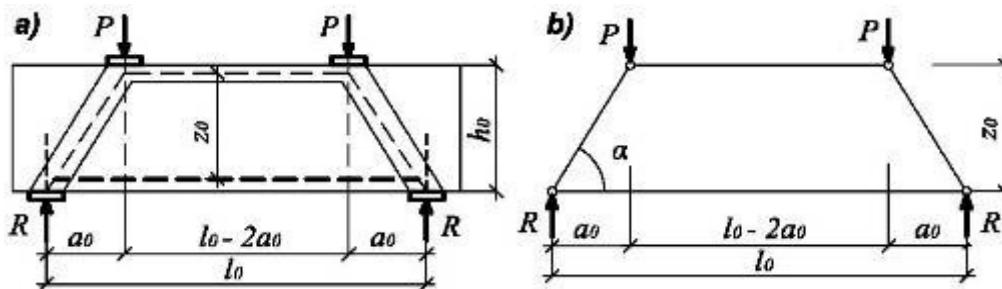

Figure 1 – Formation of force flows in usual («long») beam with small shear spans at repeated load (a) and its frame-rod analogue (b)

The principle of calculation model development is in determining of compression stresses in inclined force flows and tensile stresses in horizontal flow, intersection of which creates system, which can be conditionally called as frame-rod model of short elements. Main parameters determining calculation inclined strips are dimensions of load l_{sup}^{top} and support l_{loc}^{bot} areas, under which there are forming flows of compression stresses. The smaller is the sizes of areas, the higher is the trajectory density. So support and load areas forms incline strip and its width at top and at bottom. Angle of incline of main compression stresses flow approaches the angle of line incline which connects centers of support reaction and external concentrated force applying.

It is obvious that in process of near support area modeling of concrete element work at small shear spans using frame-rod analogue it should be considered that its fatigue strength is determined by durability of every FRS element: inclined compressed strips and strength of tensed reinforcement. Fatigue destruction of tensed elements zone occurs as a result of fatigue rupture of longitudinal reinforcement at place of intersection with inclined crack or as a result of violation of reinforcement anchoring by inclined crack. Thus, occurring stresses should be limited by values of objective concrete and reinforcement strength at cycle load (durability limit) and its friction between themselves, i.e. for provision of such reinforced concrete elements durability it is necessary to follow the durability conditions:

$$\sigma_{lc}^{max}(t) \leq f_{cd,rep}(t), \quad \sigma_{s,g}^{max}(t) \leq f_{ydp,rep}(t), \quad \sigma_s^{max}(t) \leq f_{yd,an}(t), \quad (1)$$

where $\sigma_{lc}^{max}(t)$ – compression stress on compressed force flow;

$\sigma_{s,g}^{max}(t)$ – actual tensile stresses in most loaded fibers of longitudinal reinforcement in the place of intersection with inclined crack;

$\sigma_s^{max}(t)$ – actual (maximum) axle tensile stresses in longitudinal reinforcement in the place of intersection with inclined crack;

$f_{cd,rep}(t)$ – limit of concrete durability at local compression;

$f_{ydp,rep}(t)$ – limit of reinforcement durability on tension;

$f_{yd,an}(t)$ – limit of longitudinal reinforcement anchoring durability.

Experimental researches [1, 6 – 8] have shown that stress-strain state inside inclined compression force flow is the same as in flat-stressed elements at local load. Thus, for evaluation of fatigue strength of inclined strip the model of fatigue destruction at compression and equations of objective (residual) strength of concrete and reinforced concrete at cycle load can be used. Wherein if axle «1» (fig. 2) is directed along longitudinal axle of inclined compression force flow and axle «2» in orthogonal direction and use the same designations as in elements with zero shear span, stress state inside inclined compressed force flow can be represented as fig. 2.

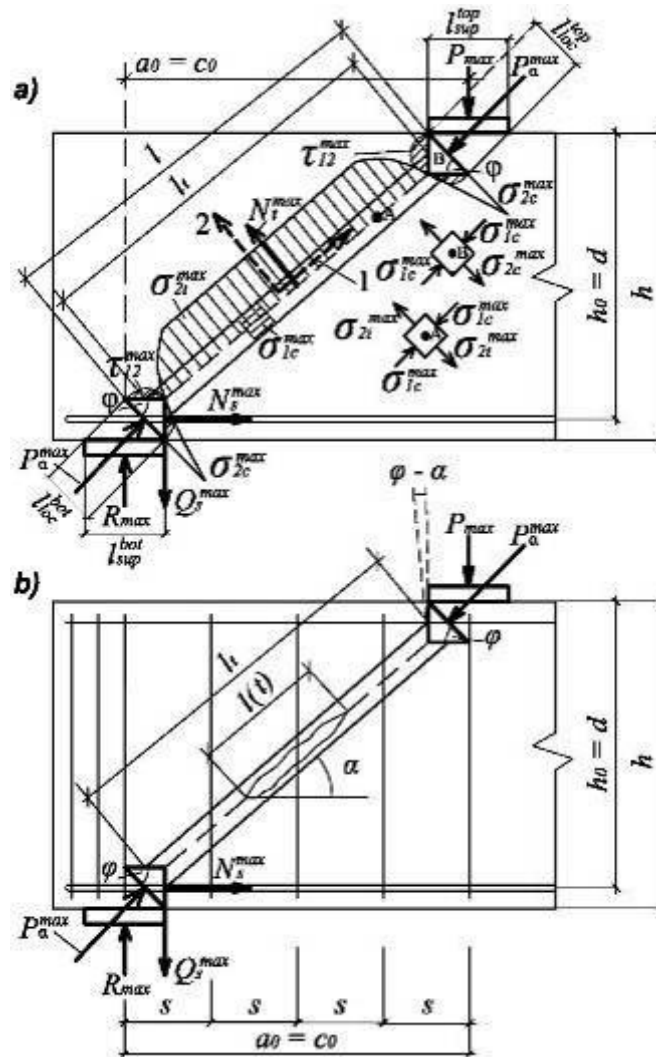

Figure 2 – Physic model (a) and calculation scheme (b) of bending reinforced concrete element resistance with small shear span at joint action of transverse force and bending moment

Since the vibro-creep deformations $\varepsilon_{lc,pl}$ extension in compressed concrete in the direction of stresses $\sigma_{lc}^{max}(t_0)$, action, as at local compression, occurs in free conditions and nothing interrupts its extension, it can be accepted that $\sigma_{lc}^{add}(t) = 0$; $\sigma_s^{add}(t) \approx 0$; $\sigma_{lc}^{max}(t) = \sigma_{lc}^{max}(t_0)$; $\sigma_s^{max}(t) \approx \sigma_s^{max}(t_0)$, $\sigma_{lc}^{max}(t_0)$ and $\sigma_s^{max}(t_0)$ slightly simple determines at first load from the conditions of equilibrium on the base of fatigue resistance model.

Because stress-strain state inside inclined compressed strip and behavior of its fatigue destruction are analogical to stress-strain state and behavior of fatigue destruction of flat-stressed elements at local load action, expression for determining of objective fatigue strength (limit of durability) of inclined compressed stripe at the moment of time t by analogy and takes the form:

$$f_{cd,rep}(t) = \frac{(k_{scf}(t) + K_{isw}(t)\cos\alpha) \cdot l_t \operatorname{ctg}\varphi}{l_{sup} \sin\alpha \sqrt{\pi l(t) Y(l)}} \times \left(A_{nn} - \left[G_c L_\varepsilon B_{nn} + \frac{6E_s I_s L_\varepsilon \cdot n \cdot \cos(\varphi - \alpha) \sin\alpha}{b \left(d_s^4 \sqrt{\frac{E_s}{E_c}} \left(1,4 + 1,25^4 \sqrt{\frac{a_s}{d_s}} \right) \right)^3 \sin\varphi} \right] \right)^{-1} \cdot \left\{ \frac{1}{E_c} + C_e \prod_{k=1}^{k=n} K_k a \psi_v + \int_{t_0}^t \frac{\partial}{\partial \tau} \left[\frac{1}{E_c(\tau)} + C(t, \tau) \right] dt \right\} \quad (2)$$

where $K_{isw}(t)$ – stress intensity factor which characterizes influence of transverse reinforcement on crack extension inside incline compressed flow;

$A_{nn} = 1$, $B_{nn} = 1/\sin^2\varphi$ – for reinforced concrete elements with load areas size $l_{sup}/h < 0,2$; $A_{nn} = \cos^2\varphi$, $B_{nn} = \operatorname{ctg}^2\varphi$ – for reinforced concrete elements with load areas sizes $l_{sup}/h \geq 0,2$; in elements without transverse reinforcement $K_{isw}(t) = 0$.

Multi-cycle fatigue of reinforcement is characterized by appear and extension of fatigue cracks in it. The formation of fatigue cracks occurs as a result of intensive plastic deformation of reinforcement steel in local volumes of stress concentration in reinforcement, main source of which is its periodic shape. It leads to significant closed hysteresis loops, which area is equal to energy, spent by one cycle of load. After plastic deformations exhausted, there microcracks appear in these local volumes, some of them can transform into large crack. At following enlargement of cycle numbers extension of main crack up to the critical size occur. Thus, for analytical description of fatigue destruction process and change of fatigue strength of steel reinforcement in reinforced concrete element at repeated loads there are used methods of destruction mechanics. The durability limit (objective strength of longitudinal reinforcement at the moment of time t at the place of its intersection with inclined crack in conditions of flat stressed state becomes:

$$f_{sd,\sigma}(t) = \sigma_{sc} \cdot k_{scf}(t) / \sqrt{(Y(l) \cdot \sigma_{sc})^2 \cdot l_s(t) + k_{scf}^2(t)}, \quad (3)$$

$$\sigma_{sc} = \frac{\sigma_u}{\left\langle 1 + \exp(-2E_s \cdot \varepsilon_{pl}^{pec} / \sigma_{su}) \sqrt{1 + 3(\tau_{si}^{max} / \sigma_{s\sigma\sigma}^{max})^2} \right\rangle}, \quad (4)$$

where $\sigma_{s\hat{a}i}^{max}$, τ_{si}^{max} – normal stresses in most loaded (tensioned) fibers and tangential stresses in longitudinal reinforcement in the place of its intersection with inclined crack;

$l_s(t)$ – length of fatigue crack in reinforcement at the moment of time t ;

k_{scf} – critical factor of reinforcement stresses intensity at repeated loads at the moment of time t ;

σ_{su} – temporary steel resistance to rupture;

ε_{pl}^{pec} – residual plastic resource of steel.

Process of multi-cycle fatigue anchoring of reinforcement is characterized by appearance and extension of fatigue cracks in contact zone between reinforcement and concrete. If the clutch stresses of reinforcement and concrete τ_g are high and these stresses are larger than limit of clutch durability, i.e. condition $\tau_g / \tau_{rep} > 1$ is true, generation and extension of through (inner) fatigue cracks occurs in contact zone between reinforcement and concrete. As it is shown in researches of B. Broms, I. Goto [9], N.I. Karpenko [3], M.M. Kholmyanskiy [10] through inner cracks cone-shaped volumes are formed. Indicated cracks permeate into concrete thickness, which crumples under these protrusions. Thus, objective fatigue strength of concrete under protrusions and forces of reinforcement protrusions clutch with concrete should be determined as function of cone-shaped crack length $l(t)$, which is permanently increasing with increasing of load cycle number. So for analytical characteristic of process of contact zone fatigue destruction and for change of longitudinal reinforcement anchoring fatigue strength at repeated loads it is also expediently to use destruction mechanic methods. Then the limit of durability (objective strength) of longitudinal reinforcement anchoring at the moment of time t is determined by:

$$\begin{aligned}
 f_{ydan,rep}(t) = & k_{scf}(t)ctg\varphi \left(\frac{1,5a}{\cos\varphi_k} - \frac{c_r}{\sin\varphi_k} \sin\varphi\cos\varphi \right) \times \\
 & \times (d + 2c_r + (0,75a - 0,5c_rctg\varphi_k\sin\varphi\cos\varphi)) \cdot (1,5 \cdot (1 + \sin\alpha_r) - \sqrt{\sin\alpha_r}) \times \\
 & \times \frac{2\tau_g(d + 2c_r)(L + L_{pl})}{d^2} \cdot (\sqrt{\pi \cdot l(t, \tau)} \cdot Y(l) s_r(d + 2c_r) \sin 2\varphi_k \sin\alpha_r)^{-1} \times \\
 & \times (1,5 \cdot (1 + \sin\alpha_r) - \sqrt{\sin\alpha_r}) \cdot \frac{2\tau_g(d + 2c_r)(L + L_{pl})}{d^2} \times \\
 & \times (\sqrt{\pi \cdot l(t, \tau)} \cdot Y(l) s_r(d + 2c_r) \sin 2\varphi_k \sin\alpha_r)^{-1} \times \\
 & \times \left\langle 1 - \frac{G_c(3atg\varphi_k - 2c_r\sin\varphi\cos\varphi)}{c_r\cos\varphi\sin^2\varphi} \cdot \frac{A_{sh}}{A_c} \left\{ \frac{1}{E_c} + C_e \prod_{k=1}^{k=n} K_k a \psi_v + \int_{t_0}^t \frac{\partial}{\partial \tau} \left[\frac{1}{E_c(\tau)} + C(t, \tau) \right] dt \right\} \right\rangle^{-1}
 \end{aligned} \quad , (5)$$

$$\text{where } \frac{A_{sh}}{A_c} = \frac{0,5\cos\varphi}{(d + c_r)} \left\{ d + 2c_r + \frac{0,5c_r\sin(\varphi - \varphi_k)}{\sin\varphi_k\cos\varphi} \right\} ;$$

d – rod diameter;

c_r, s_r, a_r – accordingly height, step and angle of reinforcement protrusions incline;

a – concrete cover;

L, L_{pl} – the length of reinforcement fastening in concrete and plastic place of this fastening;

φ_k – angle of wedge under reinforcement protrusions;

$l(t, \tau)$ – length of fatigue crack in concrete under reinforcement protrusions at the moment of time t .

During cycle loading under the influence of high stresses of concrete crumpling under the reinforcement protrusions there are intensive deformations of vibro-creep. With enlargement of load cycles number N due to concrete vibro-creep under reinforcement protrusions, which surrounds them, increasing of displacement increment $g_0^{max}(t)$ on loaded end and inside fastening $g_x^{max}(t)$ occur, and it leads to redistribution of clutch forces $P_{i,r}$ from more loaded protrusions in the end of fastening to protrusions, that are situated in the depth of fastening, i.e. occurs redistribution of clutch stresses τ_g along fastening. Wherein enlargement of load cycle number leads continuous increasing of plastic area length and increasing of completeness of clutch stress diagram.

Analysis of a number of experimental data shows that fatigue strength and limit of durability of reinforced concrete bending elements in the zone of joint action of transverse forces and bending moments exceeds appropriate stresses (loads), where inclined cracks in tensed zone of element appear even at short time static load, i.e. bending reinforced concrete structures resist to repeated cycle loads at presence of normal and inclined cracks in near support areas. Concerning it at development of calculation model for evaluation of fatigue strength or such structures durability at the transverse force and bending moment action, it is necessary to consider existence of cracks in tensed zone, because appearance and extension of inclined cracks radically changes the quality of stress-strain state especially in elements with large shear spans.

The condition of crack appear in tensed zone of bending elements on appropriate trajectories is attainment by main tensile stresses the limit of concrete tensile strength at flat stress state «compression-tension» if cracks appears on first load or fatigue strength of concrete at flat stress state, if cracks appears after some number of load cycles, including its high levels.

In elements with large shear spans ($a_0 / h_0 > 2$) in the zone of joint action of transverse forces and bending moments, at first normal cracks appear, and then at optimal quantity of longitudinal work reinforcement (in not over reinforced structures) they are warped on near support areas by trajectories of main compression stresses and transform into inclined cracks. At increasing of cycle number one of such inclined cracks starts to expend more intensive and becomes critical. Trajectory of main compression stresses with appearance and extension of initial place of critical incline crack can be described by equation $y/h = m/(n + h/a)$, where m ; n – are determined from boundary conditions. Appearance character analysis and expand of fatigue cracks, fatigue destruction of experimental beams, their stress-strain state in the zone of joint action of transverse forces and bending moments at repeated loads of high level and experimental thermograms [1] of near support areas of experimental elements allows to propose the following hypothesis of following expand of critical inclined crack and develop the physic model of fatigue destruction of bending reinforced concrete elements with large shear spans. Long before appearance of normal and inclined cracks in shear span especially before forming end expansion of critical inclined crack, in normal section at the end of shear span where maximum moment occurs, normal crack appears (section 1-1 on Fig. 3).

Until the remaining cracks appears in the zone of transverse force and bending moment action, the normal crack in the end of shear span extends on high height and tensed zone is practically fully off from work, the diagram $\sigma_x^{max}(t)$ is twisted, increases the completeness of the diagram ω_σ and in top part of it starts to form plastic area; reduction of compressed part of concrete section height which has no cracks yet leads to sharp increase of completeness of diagram ω_τ of tangential stresses and to sharp increase of maximum value of tangential stresses $\tau_{xy}^{max}(t)$. Thus, inside the plastic area x_{pl} of compressed zone it is sharply increased resulting N_{R2}^{max} of normal $N_c^{max} = \int_{A_{pl}} \sigma_x^{max}(t) \cdot dA$ and tangential $Q_c^{max} = V_c^{max} = \int_{A_{pl}} \tau_{xy}^{max}(t) \cdot dA$

forces, where A_{pl} – area of plastic part of compressed zone in normal section with crack at the end of shear span. Influenced by force N_{R2}^{max} in compressed zone, which acts in limits of limited load area $x_{pl} / \cos \gamma$, in the direction of this force action there is incline compression force flow, inclined on angle γ to longitudinal axle of element. Pattern of stress distribution inside this inclined compressed force flow is the same as at local compression. At the cycle loading even before appearance of critical inclined crack inside inclined compressed force flow from micropores in concrete body or shrinkage microcracks on the action line of tensile stresses generates and extend fatigue separation microcracks, later they join into separation macrocrack ed at angle γ to longitudinal element axle.

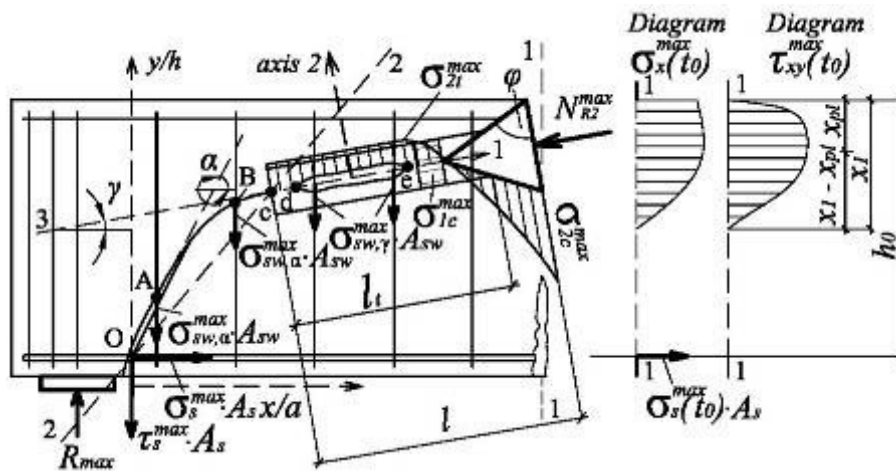

Figure 3 – Physic and calculation model of fatigue resistance of not over reinforced concrete element with large shear span

The most characteristic feature of normal separation cracks on near support parts of not over reinforced beams is tendency of any, even initially inclined to compression force action line, crack to align its trajectory in the direction of this force. Wherefrom it can be accepted the hypothesis that from all inclined cracks which were formed on near support part from joint action of transverse force and bending moment in tensed zone at first load or at increasing of cycle numbers and load levels, critical becomes the inclined crack, which comes to zone of influence of inclined compressed force flow, generated by action of resulting N_{R2}^{max} of forces in compressed zone inside plastic area x_{pl} . It can confirm that the critical crack as a rule becomes extreme (closer to support) crack, which forms and expands along less loaded trajectory of main compression stresses and the following extension of critical inclined crack and more intensive its disclosure comparing to other inclined cracks and sharp increase of normal stresses in longitudinal reinforcement in the place of its intersection with critical inclined crack, i.e. alignment of longitudinal forces.

It is known that fatigue destruction of reinforced concrete element on inclined section becomes by compressed zone or as a result of fatigue rupture of most stressed rods of transverse reinforcement which intersects with initial area of critical inclined crack, or on tensioned zone as a result of fatigue rupture of longitudinal reinforcement in normal section 1-1 or because of anchoring violation of longitudinal reinforcement on and out of support.

So for assurance of operability of element at repeated load it is necessary to adhere to conditions:

$$\sigma_{1c}^{max}(t) \leq f_{cd,rep}(t), \sigma_{sw,\alpha}^{max}(t) \leq f_{ydw,rep}(t), \sigma_{s,\beta}^{max}(t) \leq f_{ydq,rep}(t), \sigma_s^{max}(t) \leq f_{ydan,rep}(t), \quad (6)$$

where $\sigma_{1c}^{max}(t)$ – actual main compression stresses in compressed zone over critical inclined crack in the direction of resulting of longitudinal and transverse forces action inside concrete inside plastic part of compressed zone;

$f_{cd,rep}(t)$ – durability limit (objective strength) of compressed zone over critical inclined crack at local compression in the direction of main compression stresses at the moment of time t ;

$\sigma_{sw,\alpha}^{max}(t)$ – actual maximum stresses in the most loaded rods of transverse reinforcement at the moment of time t at the place of their intersection with initial part of critical inclined crack in tensed zone;

$f_{ydw,rep}(t)$ – durability limit of transverse reinforcement rods at their axle loading at the moment of time t ;

$\sigma_s^{max}(t)$ – actual maximum axle stresses in longitudinal reinforcement at the moment of time t ;

$\sigma_{s,b}^{max}(t)$ – actual maximum tension stresses in the most loaded fibers of longitudinal reinforcement at the place of intersection with inclined crack at the moment of time t ;

$f_{ydq,rep}(t)$ – endurance limit of longitudinal reinforcement in conditions of a flat stressed state at the time t ;

$f_{ydan,rep}(t)$ – durability limit of longitudinal reinforcement in conditions of flat stress state at the moment of time t .

As in elements with large shear span action of repeated load which leads to extension of vibro-creep deformations of compressed concrete in the direction of stresses σ_{xl}^{max} , σ_{lc}^{max} , action is accompanied with appearance and extension of additional (residual) stress-strain state on near support part of bended reinforced concrete element. With the aim of simplification of stress-strain state evaluation, action of repeated load and reinforced concrete element work it is expediently to divide into two stages. First stage shows stressed state of structure at first cycle ($N = 1$) of load to maximum cycle load P_{max} . Second stage is characterized by stressed state of element in the process of its repeated load ($N > 1$), which is directly continuous changed through intensive extension of vibro-creep deformations $\varepsilon_{lc, pl}$ of compressed concrete.

In general flow stresses in concrete and reinforcement and factors of cycle asymmetry becomes in form:

$$\sigma_i^{max}(t) = \sigma_i^{max}(t_0) \pm \sigma_i^{add}(t) ; \quad (7)$$

$$\rho_i(t) = \langle \rho \cdot \sigma_i^{max}(t_0) + \sigma_i^{add}(t) \rangle / \langle \sigma_i^{max}(t_0) + \sigma_i^{add}(t) \rangle , \quad (8)$$

where $\rho = P_{min} / P_{max}$, $\sigma_i^{max}(t_0)$ – initial stresses in concrete or reinforcement at first half- cycle of load;

$\sigma_i^{add}(t)$ – additional (residual) stresses in concrete or reinforcement, which appears as a result of concrete vibro-creep deformations accumulation.

Initial stresses at first load $\sigma_i^{max}(t_0)$ are determine from conditions of external and internal forces equilibrium on the base of model of fatigue resistance of element. Additional stresses $\sigma_i^{add}(t)$, which appears at process of its repeated load, starting from the second cycle of load are determined on the base of deformation relation for normal section (1-1) at the end of shear span and inclined section (2-2), which is placed on critical inclined crack (Fig. 3).

Fatigue destruction of compressed concrete zone over critical inclined crack occurs under the action of resulting N_{R2}^{max} of transverse and longitudinal forces which appears inside plastic part of normal section 1-1. Due to stress-strain state of compressed concrete zone over critical inclined crack (inside inclined compressed force flow) and behavior of fatigue destruction are analogical to stress-strain state and behavior of fatigue destruction in flat-stressed elements at the local load action, objective fatigue strength over critical inclined crack at the moment of time t we determine:

$$f_{cd,rep}(t) = \frac{(k_{scf}(t) + K_{isw}(t)) \cdot l_t \cos \gamma \cdot ctg \varphi}{x_{pl} \sqrt{\pi \cdot l(t) Y(l)}} \times \left(1 - \frac{G_c L_\varepsilon}{\sin^2 \varphi} + \frac{6 E_s I_s L_\varepsilon \cdot n \cdot \cos(\varphi - \gamma) \sin \gamma}{\left(d_s^4 \sqrt{\frac{E_s}{E_c}} \left(1,4 + 1,25^4 \sqrt{\frac{a_s}{d_s}} \right) \right)^3 \sin \varphi} \right) \times \left(\frac{1}{E_c} + C_e \prod_{k=1}^{k=n} K_k a \psi_v + \int_{t_0}^t H_\sigma \frac{\partial}{\partial \tau} \left[\frac{1}{E_c(\tau)} + C(t, \tau) \right] dt \right)^{-1} \quad (9)$$

Durability limit of longitudinal reinforcement $f_{sd,a}(t)$ at the place of its intersection with critical inclined crack in conditions of flat-stressed state is determining by (3) and (4). Durability limit of longitudinal reinforcement anchoring $f_{ydan,rep}(t)$ by critical inclined crack we determine by (5). Durability limit $f_{ydw,rep}(t)$ at axial load we determine by (3) and (4), taking at that, $\tau_{sw}^{max} = 0$.

Testing [1] reinforced concrete beams with rectangle cross section with shear span $a_0 = c_0 = (1,51 - 1,67)h_0$ allowed to specify the following picture of appearance and extension of cracks and character of fatigue destruction in the zone of transverse forces and bending moments action. Since elements with middle shear span $1,2 h_0 < c_0 = a_0 < 2 h_0$ are on borders of elements with small and large shear spans, in their operating and in mechanics of fatigue destruction at middle shear spans there are determined features of first and second, i.e. on the behavior of appearance and extension of cracks in the zone of transverse force and bending moment action and fatigue destruction of these elements has influence as internal force factors, as local fields of stress state and stresses concentration in corresponding zones in places of concentrated external forces applying. Thus, at middle shear spans fatigue destruction occurs with appearance of critical inclined crack, but local fields of stressed state and concentration of stresses in indicated zones have influence on destruction. Critical inclined crack can appear on the distance $(0,2...0,3)h$ from the tensed edge and extends in support or concentrate external force direction. In tensed zone it disclosures along line 2-2 (fig. 4) which connects inner edge of supporting plate with external edge of load plate and fully intersects (to inner edge of support plate).

But in its extension from support to concentrated force critical inclined crack after approaching point O , i.e. intersection of lines 2-2 and 3-3, changes its direction and resume extension along line 3-3 by the axle of inclined compressed flow. At the same time inside compressed force flow on the line of tensile stresses σ_{2t}^{max} appears and extents rupture crack $d - e$ along axle 3-3, which afterwards merges initial part OO_2 of critical crack. It is obvious that appearance, extension and disclosure of critical crack in tensed zone (area OO_2) are connected with flat rotation and shear of inclined section 2-2, and its extension and disclosure in compressed zone (ed) are caused by appearance and extension of rupture microcracks on the line of tensile stresses σ_{2t}^{max} (Fig. 4) action in the zone «tension-compression» inside inclined compressed force flow, formed under the action of force P_β^{max} , and following merge into macrocrack with following extension and disclosing of this rupture macrocrack. Behaviour of stress distribution inside inclined compressed force flow is the same as at crumpling.

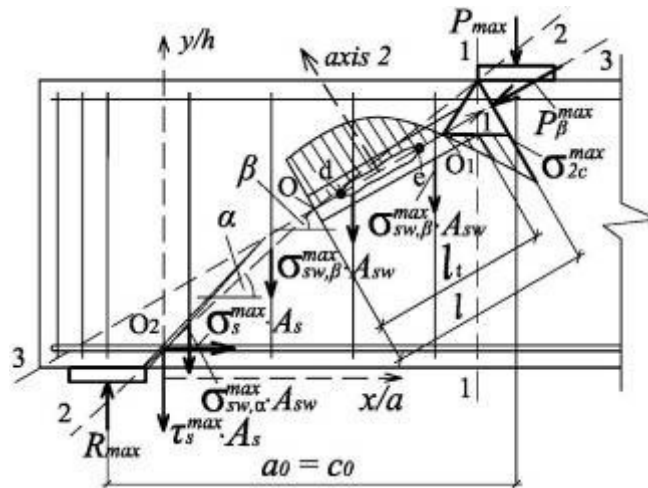

Figure 4 – Physic model and calculation scheme of fatigue resistance of inclined not over reinforced element with middle shear span

For this cause of stress-strain state and destruction character objective fatigue strength (durability limit) of inclined concrete strip over critical inclined crack becomes:

$$f_{cd,rep}(t) = \frac{(k_{scf}(t) + K_{isw}(t)) \cdot l_t \cdot ctg\varphi}{l_{sup} \sin\beta \sqrt{\pi \cdot l(t) Y(l)}} \times \left\langle \left\{ 1 - \frac{G_c L_\varepsilon}{\sin^2 \varphi} + \frac{6 E_s I_s L_\varepsilon \cdot n \cdot \cos(\varphi - \beta) \sin\beta}{\left(d_s^4 \sqrt{\frac{E_s}{E_c}} \left(1,4 + 1,25^4 \sqrt{\frac{a_s}{d_s}} \right)^3 \right) \sin\varphi} \right\} \times \right\rangle^{-1} \cdot (10)$$

$$\left\{ \frac{1}{E_c} + C_e \prod_{k=1}^{k=n} K_k a \psi_v + \int_{t_0}^t \frac{\partial}{\partial \tau} \left[\frac{1}{E_c(\tau)} + C(t, \tau) \right] dt \right\}$$

Durability limits of transverse and longitudinal reinforcement and durability limit of its anchoring is determined by (3), (4) and (5).

Conclusions. Thus, the calculation of reinforced concrete structures at joint action of transverse forces and bending moments presence methods analysis, based on the researches [1 – 6, 11 – 13] shows that in most cases they perform in assumption of elastic concrete work without considering its physic nonlinearity and change of deformation modes of materials in structures at cycle loading.

Considering physical models and calculation schemes of near support areas resistance of not over reinforced span reinforced concrete structures to repeated load of high level, there are envisaged different types of fatigue destruction of materials considering vibro-creep deformations, accumulation of damages in form of fatigue micro- and macrocracks.

References

1. Мирсаяпов И. Т. Выносливость железобетонных конструкций при действии поперечных сил: автореф. дис. на соиск. науч. степени канд. техн. наук: спец. 05.23.01 – строительные конструкции, здания и сооружения / Илшат Талгатович Мирсаяпов. – Казань, 2009. – 39 с.
2. Бабич Є. М. Бетонні та залізобетонні елементи в умовах малоциклових навантажень / Є. М. Бабич, Ю. О. Крусь. – Рівне, РДТУ, 1999. – 120 с. ISBN 966-7447-05-7.
3. Карпенко Н. И. Общие модели механики железобетона / Н. И. Карпенко. – М. : Стройиздат, 1996. – 416 с.

4. Aslani F. *Stress-Strain Model for Concrete under Cyclic loading* / F. Aslani, R. Jowkarmeimandi // *Magazine of Concrete Research, ICE Publishing*. – Woollongong, 2012. – Vol. 64, Is. 8. – P. 673 – 685.
DOI 10.1680/mac.11.00120.
5. Trapko W. *Load-Bearing Capacity of Compressed Concrete Elements Subjected to Repeated Load Strengthened with CFRP Materials* / W. Trapko, T. Trapko // *Journal of Civil Engineering and Management*. – Wroclaw, Poland, 2012. – Vol. 18, Is. 4. – P. 590.
DOI 10.3846/13923730.2012.701664
6. Соколов Б. С. *Новый подход к расчёту прочности бетонных элементов при местном действии нагрузки* / Б. С. Соколов // *Бетон и железобетон*. – 1992. – №10. – С. 22 – 24.
7. Баранова Т. И. *Каркасно-стержневые расчётные модели и инженерные методы расчёта железобетонных конструкций* / Т. И. Баранова, А. С. Залесов. – М. : Изд-во Ассоциации строительных вузов, 2003. – 239 с.
ISBN 978-5-93093-193-8.
8. *Расчёт железобетонных конструкций по прочности, трещиностойкости и деформациям* / А. С. Залесов, Э. Н. Кодыш, Л. Л. Лемыш, И. К. Никитин. – М. : Стройиздат, 1988. – 320 с.
9. Goto I. *Cracks formed in concrete around deformed tension bars* / I. Goto // *ACI Journal*, 1971. – Volume 68, Issue 4. – P. 73 – 79.
10. Холмянский М. М. *Бетон и железобетон: деформативность и прочность* / М. М. Холмянский. – М. : Стройиздат, 1997. – 570 с.
11. *Behaviour of Reinforced Concrete Beams Strengthened with Basalt Textile Reinforced Concrete* / S. Gopinath, R. Murthy, N. Relyer, M. Prabha // *Journal of Industrial Textiles*, 2015. – Vol. 44, Is. 6. – 924 p.
DOI 10.1177/1528083714521068
12. Toothman A. J. *Monotonic and Cyclic Performance of Light-Frame Shear Walls with Various Sheathing Materials: Thesis of Master of Science in Civil Engineering* / A. J. Toothman. – Blacksburg, Virginia, 2003. – 154 p.
13. Naghibdehi M. *Behaviour of Functionally Graded Reinforced-Concrete Beams Under Cyclic loading* / M. Naghibdehi, M. Naghipour, M. Rabiee // *Gradevinar*. – 2015. – Vol. 67, Is. 5. – P. 427 – 439.
DOI 10.14256/JCE.1124.2014

© Karpiuk V.M., Kostiuk A.I., Somina Yu.A.